

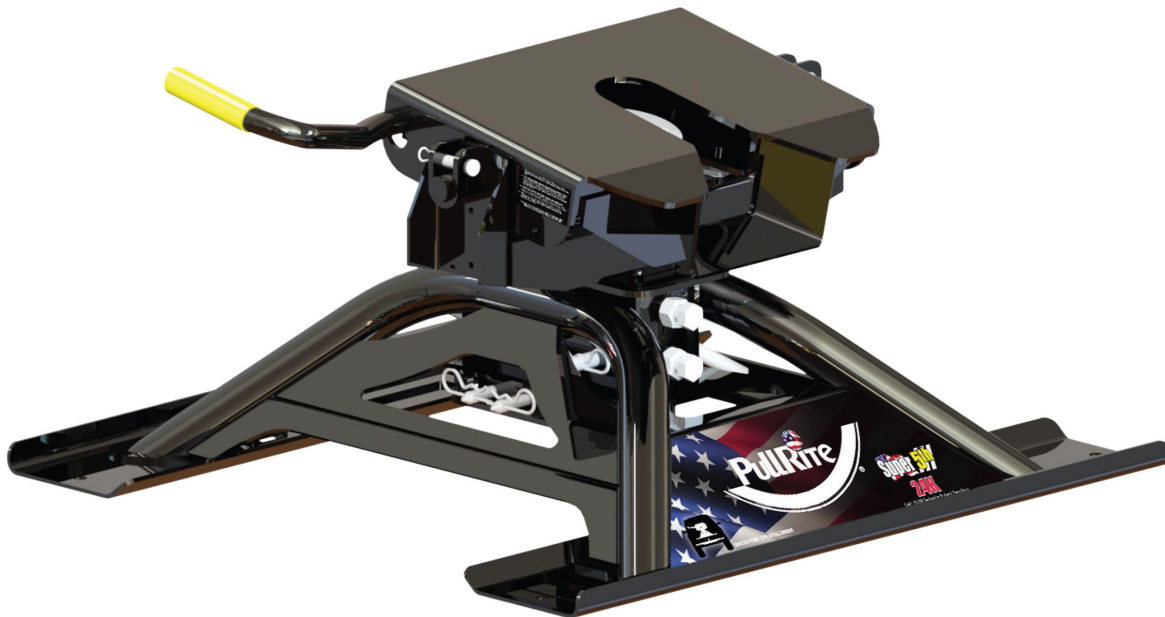

# OWNER'S MANUAL



**#3900 (24K)**

## Single Point Attachment Fifth Wheel Hitch

Gross Trailer Weight (Maximum) ..... 24,000 lbs.

Vertical Load Weight (Max. Pin Weight)...6,000 lbs.

The following instructions provide valuable information regarding the function and proper use of the Super 5th Towing System.

*YOU MUST COMPLETELY READ THE INSTRUCTIONS WITHIN THIS MANUAL, PRIOR TO OPERATING THE HITCH TO PREVENT UNNECESSARY DAMAGE TO THE HITCH, VEHICLE, OR TRAILER.*

For more information, please call PullRite at (800) 443-2307.

7.18.22 Rev B RH

# TABLE OF CONTENTS

SYSTEM WEIGHT RATING vs. COMPONENT WEIGHT RATING.....	3
CAB CLEARANCE.....	3
GM TRUCK SUPPORT INFO.....	4,5
KING PIN ADAPTER BALL & COUPLER TUBE.....	6
BED SAVER RAILS.....	6
ANNUAL MAINTANANCE.....	6
HEIGHT ADJUSTMENT.....	7
FIFTH WHEEL PLATE OPERATION.....	8,9
GOOSENECK RECEIVER INSTALLATION.....	10
ATTACHING THE HITCH.....	11
HITCHING.....	12
SAFETY CHECKS PRIOR TO TOWING.....	12
UNHITCHING.....	13
CHALLENGE VS SOLUTION.....	13
RELATED ACCESSORIES.....	14
TORQUE TABLE.....	15
#3900 EXPLODED VIEW.....	16
#3900 PARTS LIST.....	17
YEAR LIMITED WARRANTY.....	i
PRODUCT REGISTRATION.....	ii

## SYSTEM WEIGHT RATING vs. COMPONENT WEIGHT RATING

A towing system includes each vehicle and component involved in towing. Each item in your towing system has a capacity or weight rating. Your trailer has a Gross Vehicle Weight Rating or GVWR. Your truck has a towing capacity, a payload capacity, and possibly more. In addition, your fifth wheel hitch has a weight rating. This weight rating must be at, or above, the GVWR of your trailer for you to tow safely. In addition, if your truck can tow larger loads (has a larger capacity) than the rating of your hitch, your system is only safe to tow loads at the lower rating, that of the hitch.

Your gooseneck ball will also have a weight rating, just like your fifth wheel hitch. Many times, these ratings are designed to match, but this is not always the case. Your gooseneck ball may be higher rated than your fifth wheel hitch, but it also could be lower depending on the components involved. The lowest rating of any one component in the system becomes the rating of the entire system. If your ball is rated to 18,000 lbs., and your hitch is rated at 24,000 lbs., the weight rating of the entire system will not be above 18,000 lbs. Other components in the system could lower the actual system rating further.

It is the end users responsibility to ensure a safe towing experience. To this end, it is your responsibility to ensure that the truck, trailer, hitching components, and all other items involved are rated or have a capacity sufficient for the loads involved.

## CAB CLEARANCE

If you are towing with a short bed truck, you may be aware that adequate cab clearance is needed for sharp angle turns and damage to the truck cab could occur if the clearance is not calculated correctly.

This formula is a guide for checking clearance: (cab to axle) - (half of the trailer width) = cab clearance

Here are a few examples:

BED LENGTH	CAB-TO-AXLE DIST.	CAB-TO-TRAILER CLEARANCE
8 ft.	56"	56" - 48" = 8" of cab clearance
6 ft.	40"	40" - 48" = - 8" negative cab clearance
5-1/2 ft.	28-1/4"	28.25" - 48" = -19.75 negative cab clearance

As you can see, an 8' bed truck provides more clearance than needed, whereas a 6' bed truck does not allow for a full 90 degree turn and does not provide sufficient cab clearance by 8". Not ideal, but manageable provided you watch your tighter turns. The 5-1/2' bed truck provides even less cab clearance.

If towing with a truck bed that is 6 ft. or less, you must take into consideration that most gooseneck ball installations are located ahead of the truck axle, which in turn reduces the trailer to cab clearance. This hitch will provide a minimum of 3 1/4" and a maximum of 4 3/4" of rearward offset to the trailer king pin. This additional offset may or may not return the king pin back to the center of the axle. Depending on the gooseneck ball install location, the offset could move the king pin slightly behind the truck's rear axle.

While the #3900 can be used with these shorter bed trucks, keep in mind that PullRite only recommends the use of a SuperGlide slider hitch for any towing application without 100% cab clearance.

# GM TRUCK SUPPORT BRACKET KIT #2616

REQUIRED WHEN USING THE #3900 SUPER 5TH IN GM TRUCKS FROM YEARS 2010 - PRESENT

The #3900 hitch requires the support of the truck bed and under bed support features, however, GM trucks lack sufficient support at the rear location for this type of hitch. GM trucks will require this kit to reach the stated load capacity for this hitch. These brackets fasten under the GM truck bed to the frame where the rearward rail of the hitch is situated to provide the needed support. This kit is a no-drill install that clamps around the truck frame on both sides.

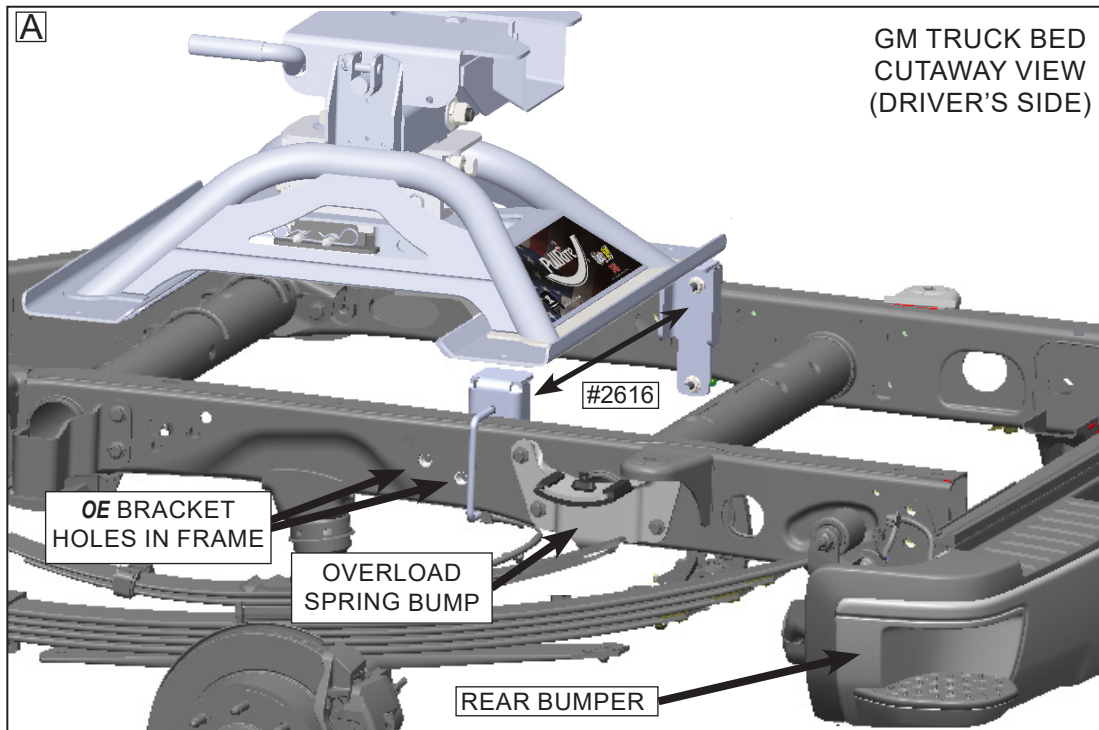

**Note:** The brackets are identical and can be used for either side.

To Install, make sure top of the brackets are placed below the #3900 rearward bed saver rail. {fig.A}

1. Place U-bolt around the truck frame at the point between the OE bracket holes and the overload spring bump. {fig.C}. and slide on brackets inside truck frame. *If OE bracket is present, your truck is equipped with the OE prep package. For this application, you will need the PullRite OE Puck Plug kit #2620.*
2. Hand tighten (4) flange nuts on brackets {fig D}, and then torque all nuts to 75 foot pounds.

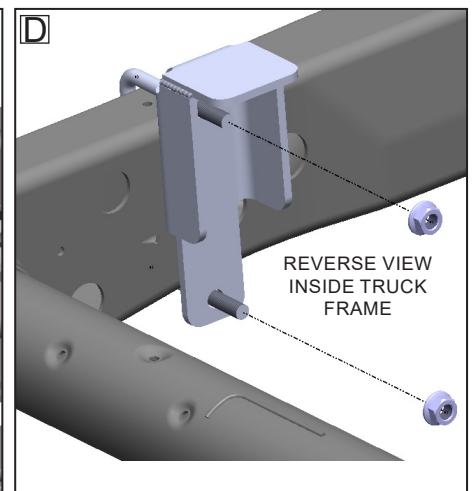
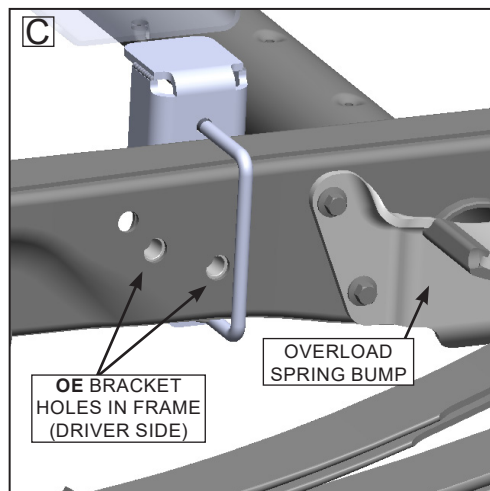
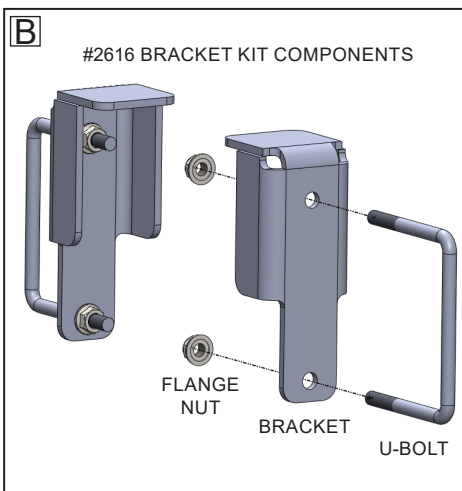

# GM OE PUCK PLUG KIT #2620

## SUPER 5th #3900 SUPPORT FOR GM TRUCKS WITH OE PREP PACKAGE

If your GM truck features the OE prep package for towing, use the GM OE Puck Plug kit (part #2620) in place of the #2616 kit. The plugs fill the gap between truck bed and the tops of the pucks, adding bed support to the #3900 to reach the stated load capacity for this hitch.

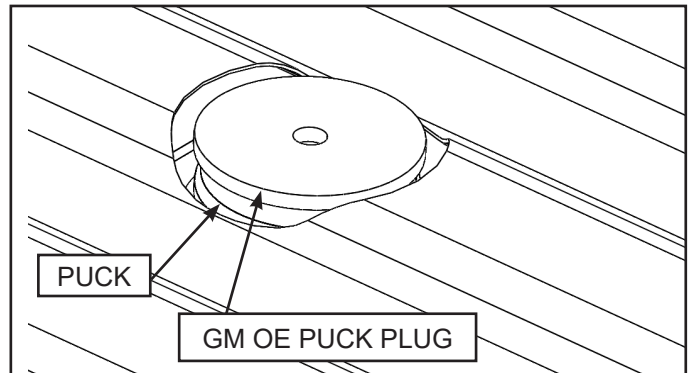
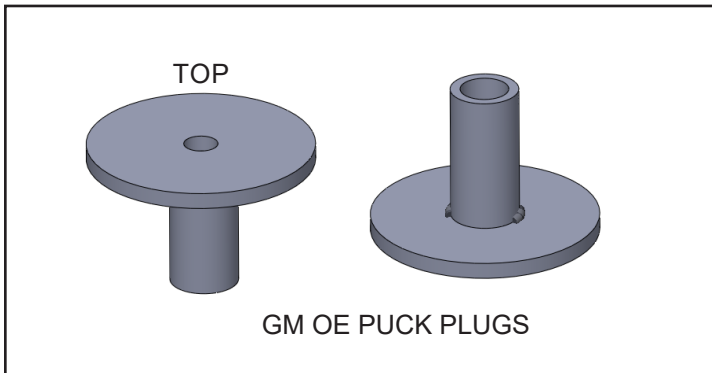

### KIT INSTRUCTIONS:

- First, remove the (4) OE Puck Covers.
- Holding the top of the plug, place the bottom of the Plug into the GM Puck. The Plug will fit loosely. Center within hole.
- Repeat with the other three plugs. Make sure all (4) plugs are set into each puck location.
- The PullRite #3900 hitch is ready to Install.

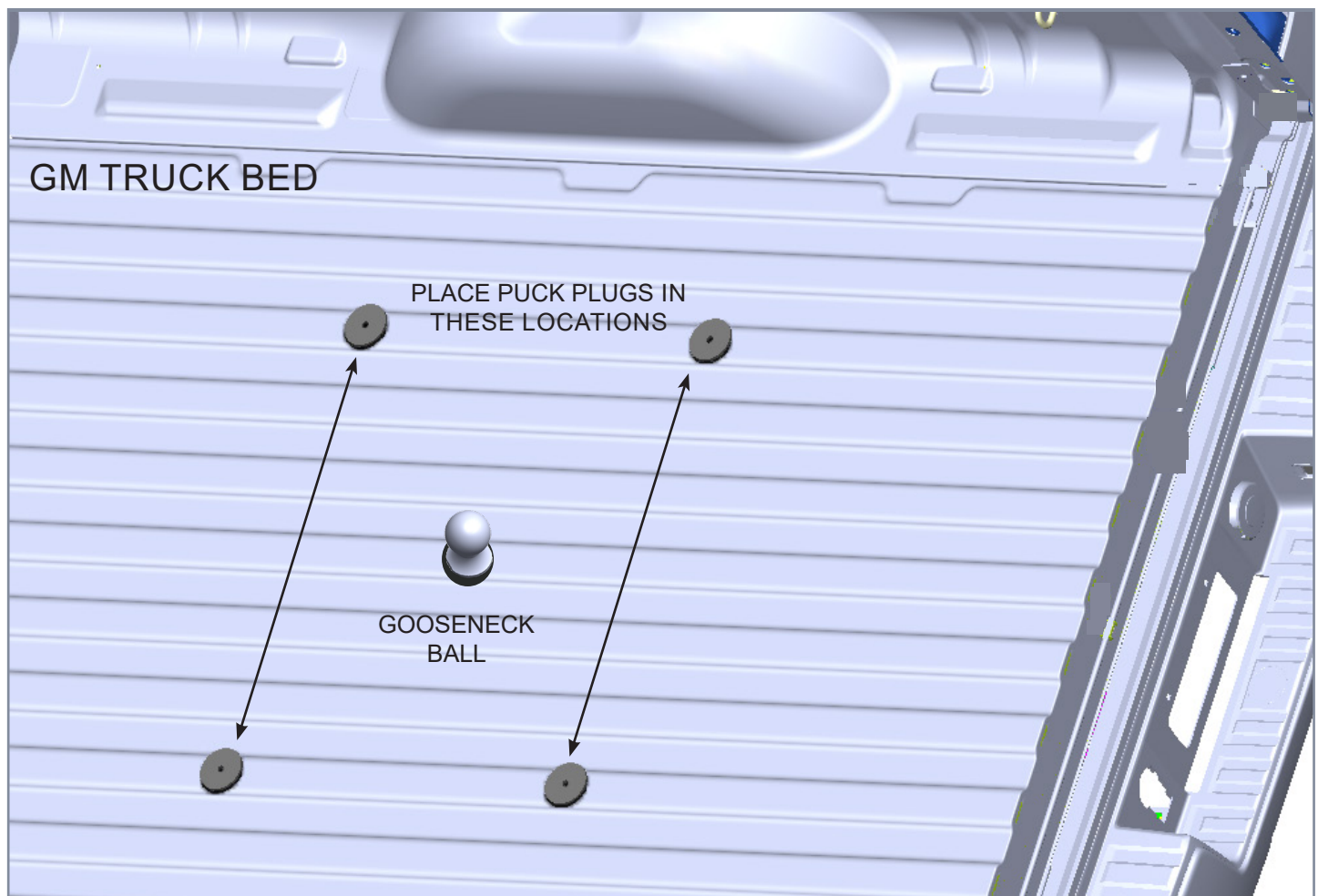

## LUBRICATION

**DO NOT OPERATE HITCH UNTIL YOU READ THIS SECTION!**

### HEAD PLATE ASSEMBLY

The Head Plate must be lubricated before each trip or as needed. PullRite recommends using a light lubricant spray such as WD-40 or 3-IN-ONE Oil to prevent the attraction of dust and debris.

Be sure the inside of the Head Plate is free of any obstructions prior to lubrication and before each use, check the Latch System's locking mechanism to ensure it is in working order.

When lubricating the Latch System using a dry graphite spray, place the Latch System in both closed and open positions to cover the spring and pin effectively. If using a wet lube, pull the Release Handle repeatedly between the open and closed positions, so the lubricant is evenly spread among the moving parts.

Be sure the King Pin is clean and free from rust. A light coating of wet lubricant should be used before each trip or as needed.

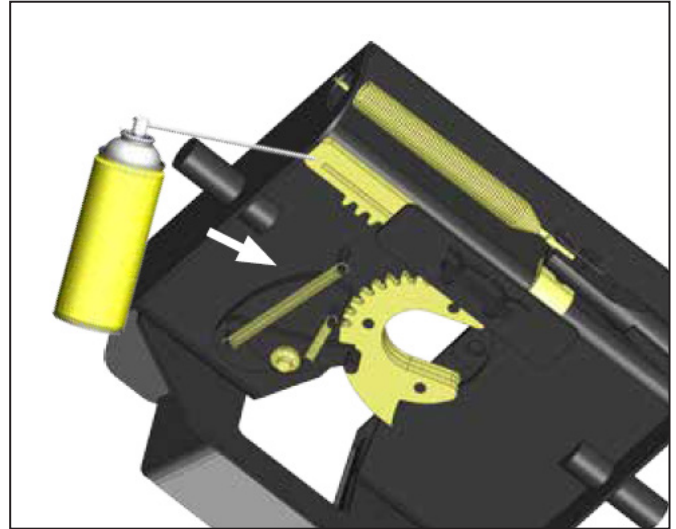

### BED SAVER RAILS

The Bed Saver Rails connect to the bottom of the hitch and are coated with bed liner type material to protect your truck bed against scratches, paint wear, and galvanic corrosion when in contact with aluminum truck beds. These Bed Saver Rails are engineered to distribute the weight of the load more evenly, also to keep the hitch from laterally rotating out of its intended position. Because these Bed Saver Rails absorb the vibration movement of the hitch, use a spray like WD-40 for the areas on top where the Hitch Base makes contact. An alternative to lube would be to use our Plastic Slide Kit. See accessories on page 14 for details.

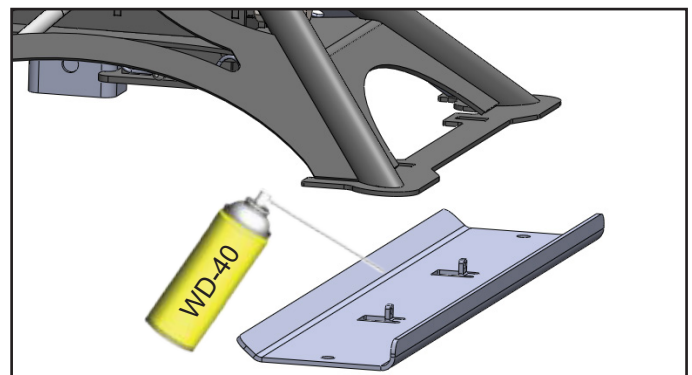
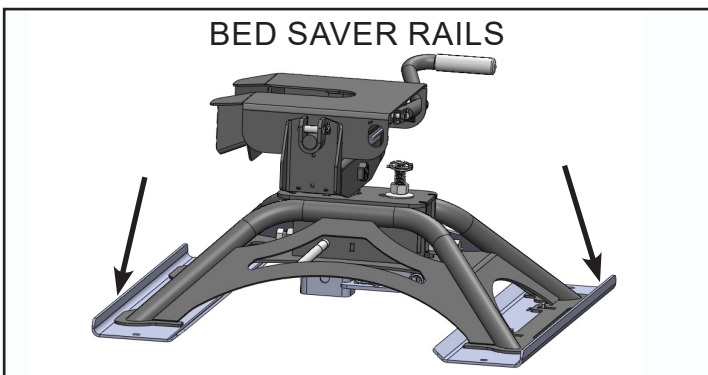

### ANNUAL MAINTENANCE

Inspect all hitch hardware to verify that it is securely fastened. Inspect set screws and bolts for tightness and general condition. When storing your Super 5th hitch, you should be sure that the latch mechanism and hitch parts are lubricated with WD-40, or dry graphite spray like Slip Plate brand (#33040301). Use wet lube for wear areas such as the contact area between the Hitch Base and the Bed Saver Rails where the paint may rub off and form rust. Cover the entire assembly to prevent accumulation of dirt, grime, and rust.

# HEIGHT ADJUSTMENT

The Super 5th #3900 is height adjustable and can be set at three positions. Refer to the illustration below and the #3900 exploded view drawing on page 10, following each step below to adjust your hitch's height:

1. Loosen the two column jam nuts (7/8" socket) as well as the two bolts (3/4" socket). It is not necessary to remove the bolts - just back out about two complete turns or until the column is loose in the base.
2. Remove the bent hitch pin and clip and adjust to the desired height.
3. Re-pin and clip.
4. Torque the two set screws first to 45 ft. lbs., then tighten the jam nuts to 45 ft. lbs. as well. *Over-tightening these set screws could cause damage to the base. Always torque properly.*

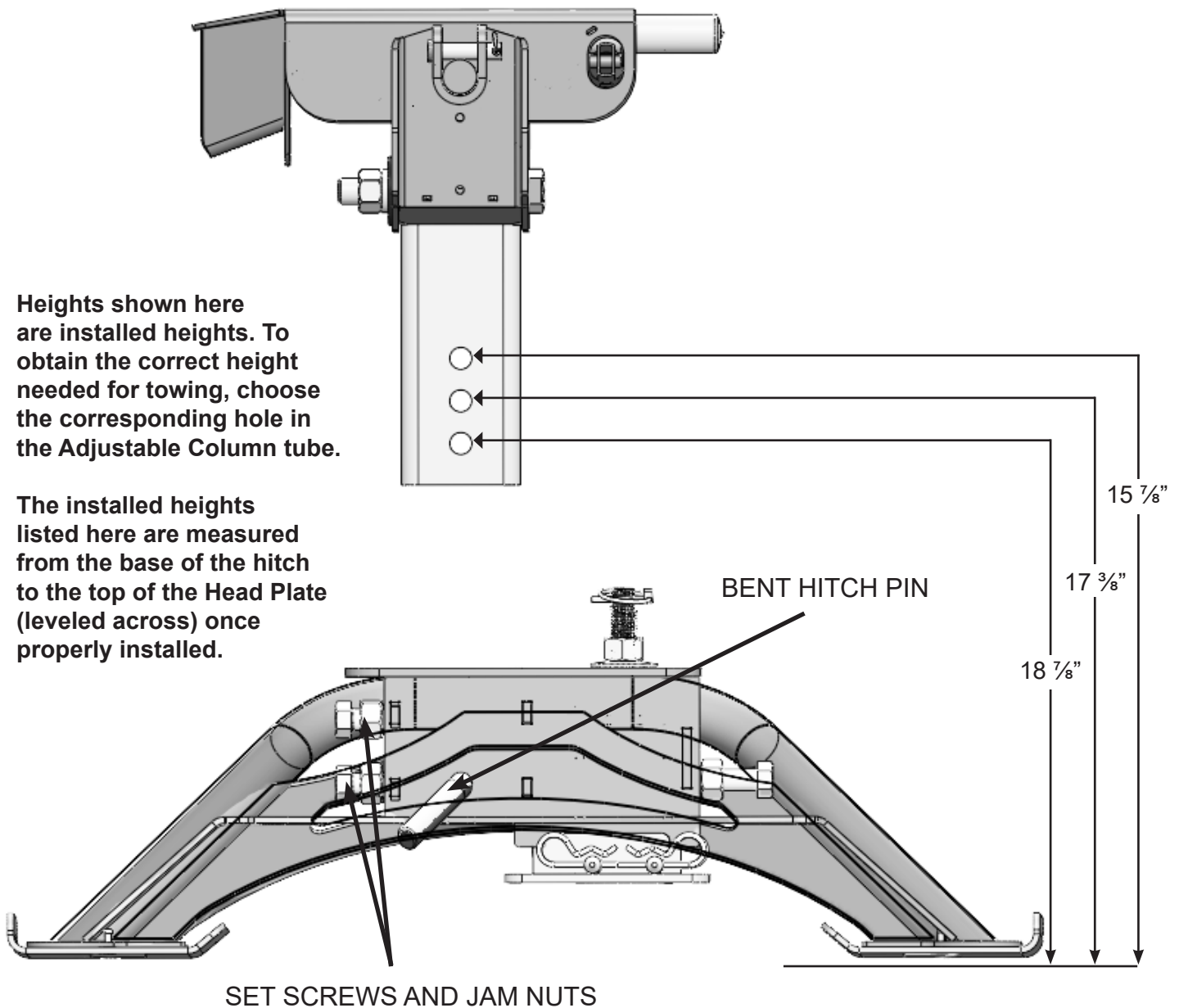

# FIFTH WHEEL PLATE OPERATION

A better understanding of the plates locking and unlocking operation can be obtained by viewing the working parts from the underside of the plate. The Fifth Wheel Plate can be removed and turned over to view the workings of the mechanism. When operating the Fifth Wheel Plate manually, please be aware that the Lock Jaw Assembly has more movement capability when there is not a king pin present to center the assembly.

1. To open the locking mechanism, lift and pull the Release Handle out until the Lock Catch engages the Lock Jaw Assembly.
2. As the trailer king pin moves into the plate, it will contact the Lock Lever, forcing the Lock Catch to disengage the Lock Jaw Assembly, allowing the Lock Bar Spring to close the Lock Jaw Assembly behind the King Pin. The King Pin must be fully engaged in the plate slot or the Lock Jaw Assembly will not seat properly, and the Handle Catch would not then engage the inner side wall of the plate. To be certain that the Lock Jaw Assembly has closed fully, attempt to pull the Release Handle without first lifting it.

NOTE: Please note that when lifting the handle to clear the side wall of the plate with the handle catch, it will be necessary to pull with some force to begin the Lock Jaw rotation. Merely lifting the Release Handle will not cause the Handle to “pop” open and rotate the Lock Jaw to the open position.

## #3601 HEAD PLATE

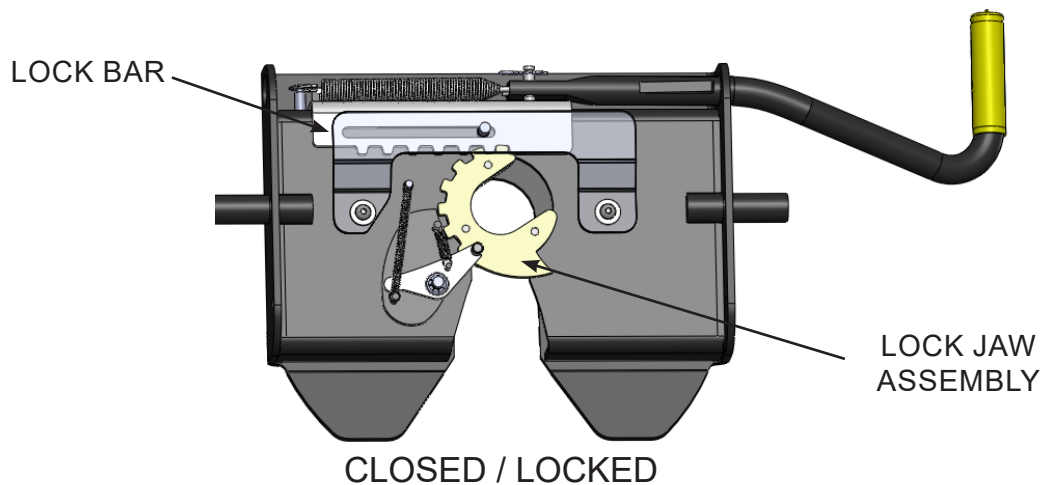
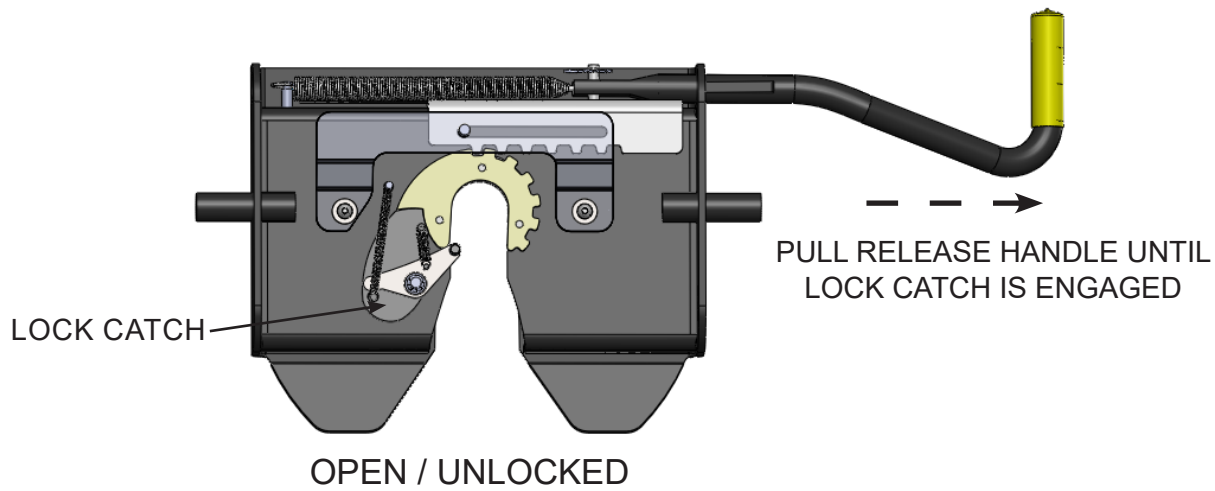



# FIFTH WHEEL PLATE OPERATION

CAUTION: DO NOT ATTEMPT TO TRIP THE LOCK MECHANISM WITH YOUR HAND.  
USE A PROBE DEVICE TO SIMULATE THE KING PIN ACTION

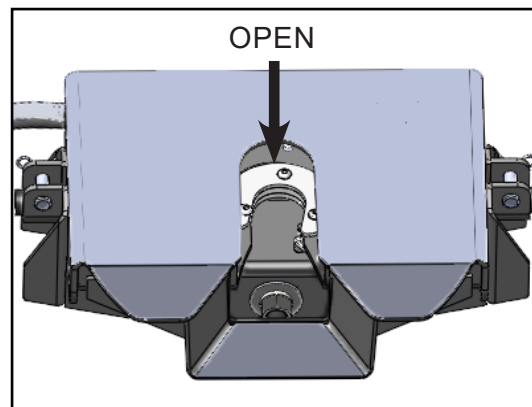
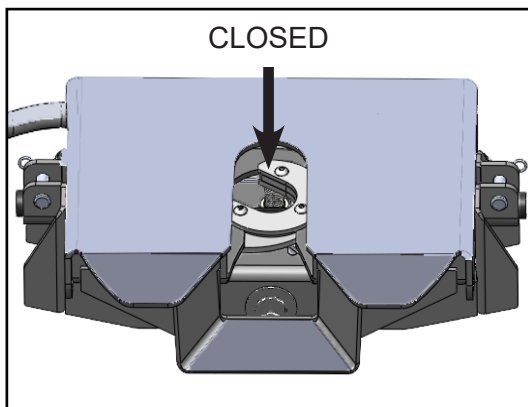
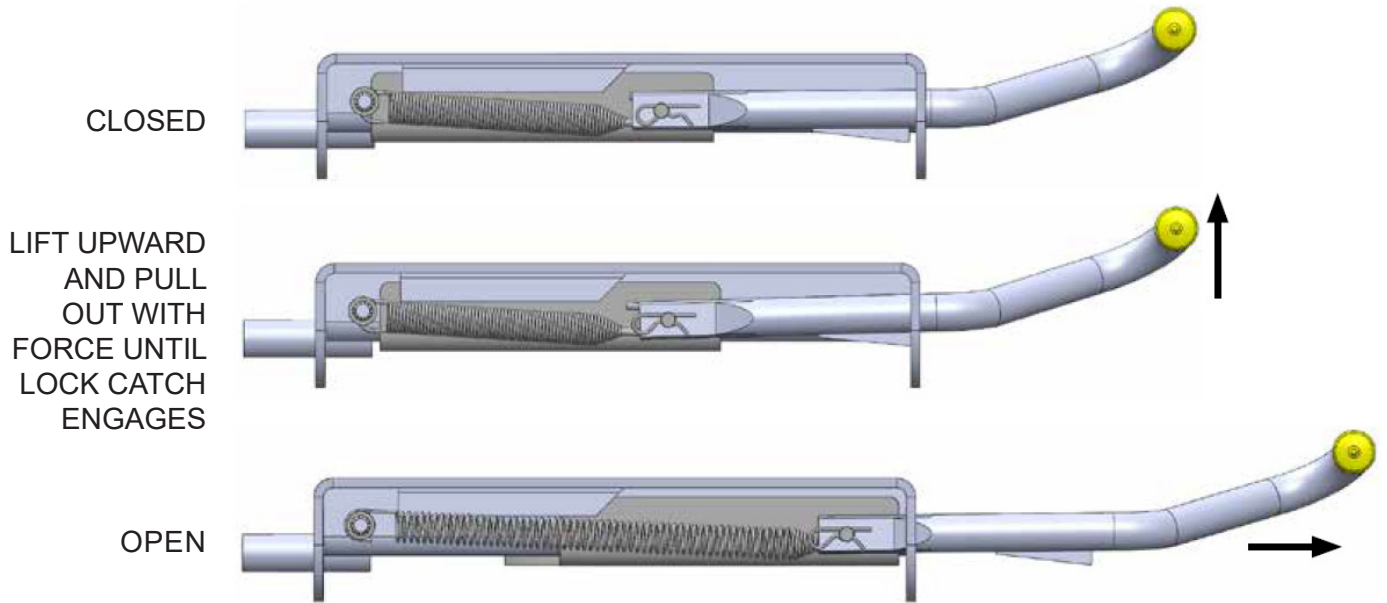

# GOOSENECK RECEIVER INSTALLATION

The Gooseneck Receiver is the box that fastens to the original equipment (prep kit) gooseneck ball or aftermarket gooseneck ball (2 5/16", 30,000 lbs rated) in the bed of the truck. Its purpose is to secure the connection of the hitch to the truck bed by way of the Draw Down Bolt (3/4" X 4" carriage bolt). The Gooseneck Receiver can be adjusted 1 inch in either the forward or rearward direction as needed. See the "ABOVE VIEW" diagram below left on this page.

1. Place Gooseneck Receiver over the ball in the truck bed as shown below. Connect with provided clevis pins through the (2) holes in the bottom of the Gooseneck Receiver. Then fasten hairpin clips through clevis pins on both sides.
2. Make sure Gooseneck Receiver is facing one of the two directions as shown in the "ABOVE VIEW" diagram to ensure the hitch is placed in the correct position.

## GOOSENECK RECEIVER

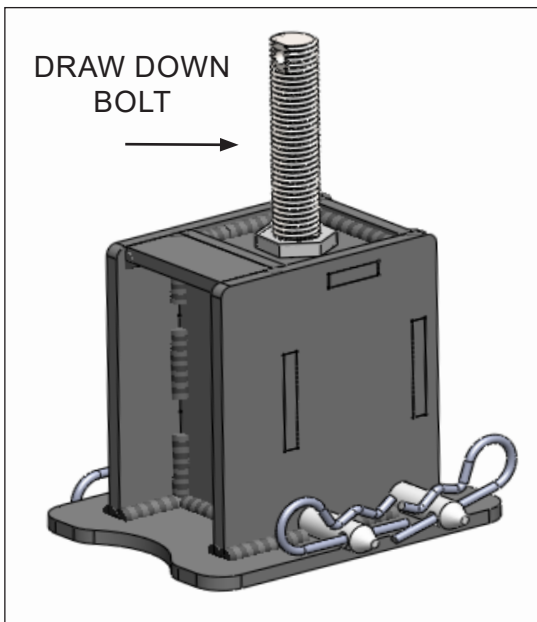

ABOVE VIEW

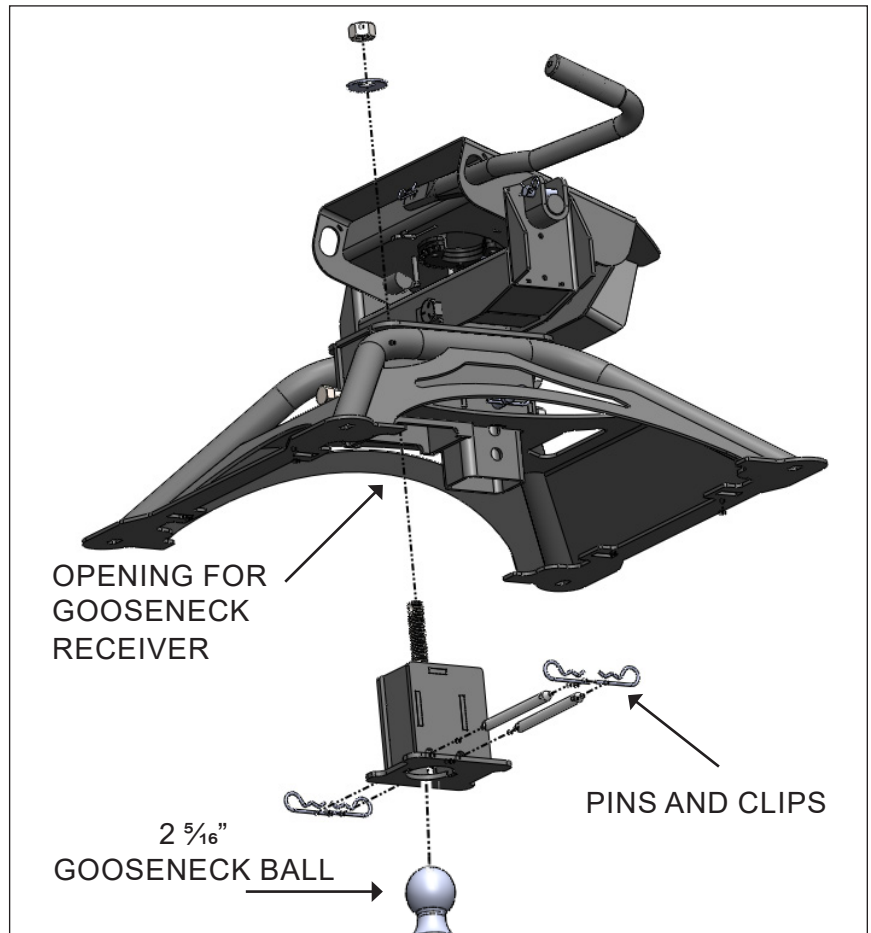
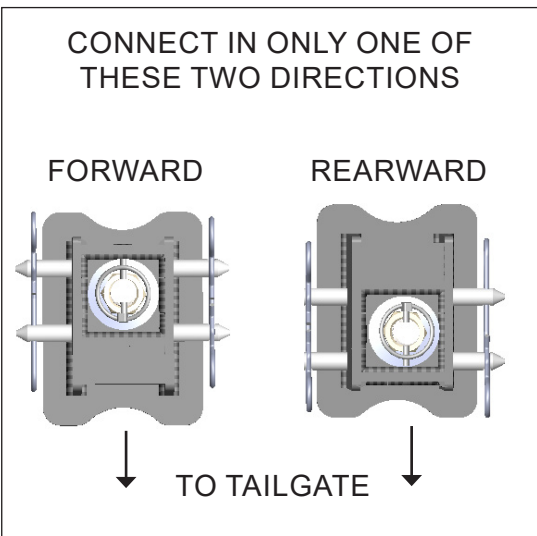
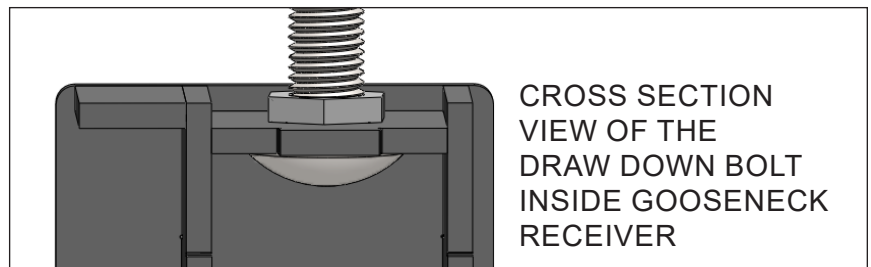

# ATTACHING THE HITCH

1. Set the hitch over the Gooseneck Receiver with the PullRite logo plate facing the truck tailgate. Make sure that the Draw Down Bolt from the Gooseneck Receiver extends up through the oval slot in the top of the hitch behind the Head Plate. Slide the Bed Saver Rails in place under hitch feet (**90° angle facing outward as seen in diagram at right**). Once the hitch is seated, the next step is to fasten the hitch down to the truck bed.
2. Place the Conical Tooth Washer (teeth down) over the Draw Down Bolt to the hitch, and then thread on the Draw Down Nut. Use a torque wrench to tighten the nut to 60 foot pounds. As an extra measure of security, insert the provided lynch pin through the hole in top of Draw Down Bolt above the nut and snap ring over into the lock position.
3. Locate the set screw and jam nut on the front of the hitch facing the truck cab. Tighten the set screw to 45 foot pounds using a torque wrench, and then snug tighten the jam nut. Make sure hitch is tight against the truck bed.

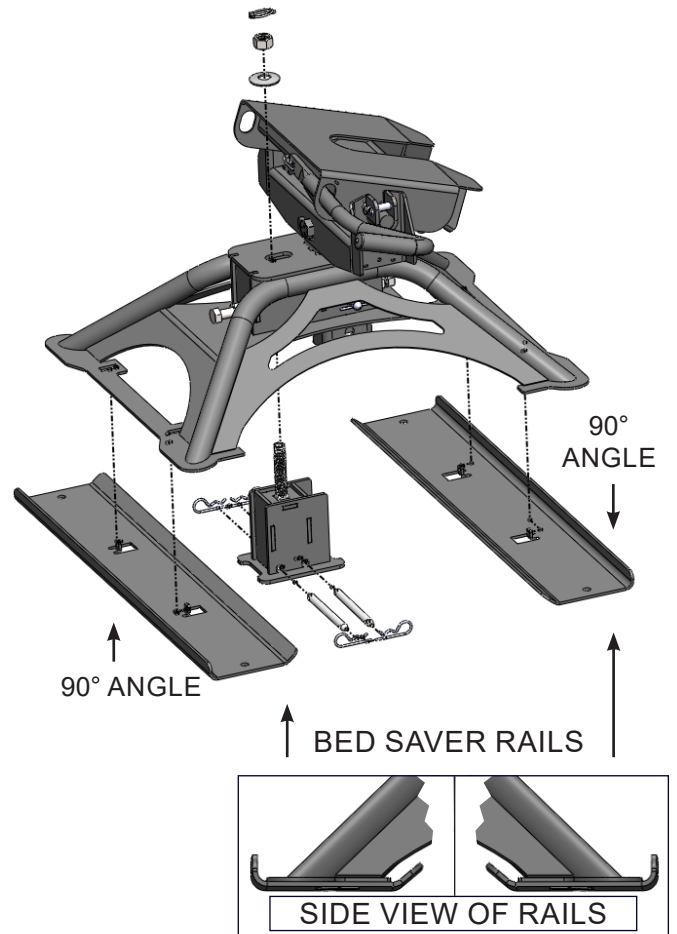

**Warning:** The Draw Down Bolt and fasteners are the only bolt holding your hitch in place, care should be given to make sure that each time you install your hitch, you have inspected each fastening element for wear, corrosion, crossed threads or any unusual appearance. you should also check the torque of the Draw Down Nut between each use.

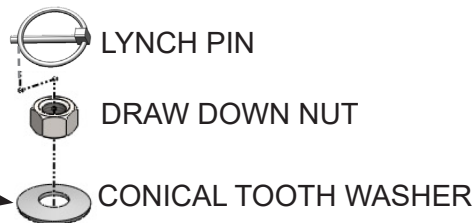

DRAW DOWN BOLT FROM GOOSENECK RECEIVER

OVAL SLOT

SET SCREW & JAM NUT

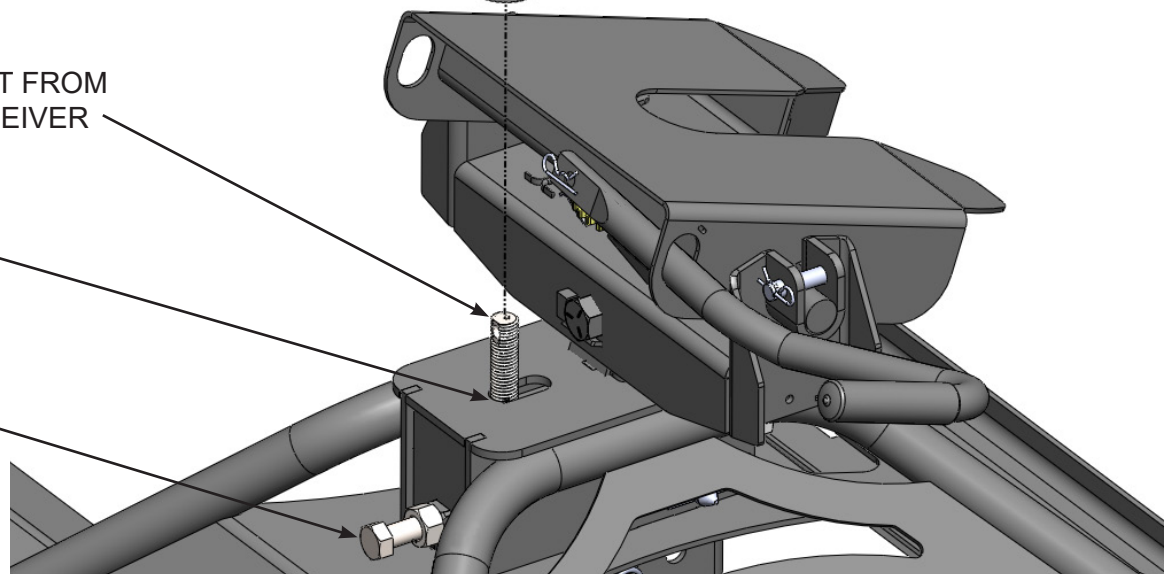

# HITCHING

**WARNING:** Never perform any of the following actions while any part of a person is between the vehicle and trailer.

1. Align your truck with the center of the trailer. The truck should be close to parallel to the centerline of the trailer.
2. Block the trailer wheels so the trailer will not roll back.
3. Lower your tailgate and back up until there is about 6" of clearance between the Super 5th and the end of the fifth wheel plate. Raise or lower the front of the trailer so the bottom of the plate is aligned slightly above the beginning of the ramp area of the Fifth Wheel Plate (Fig. A). This procedure will cause the front edge of the trailer plate to "ride up" the ramp and flatten or tilt the hitch plate into a parallel position.

**CAUTION:** If this procedure is not followed, the king pin may bind in the plate mechanism and not lock-in properly. Following the procedure as outlined in Step 3 will ensure that you will not "high hook" the king pin in the plate. "High hooking" occurs when backing your hitch into a trailer that is set too high, resulting in the lower flange of the king pin to wedge itself against the metal edge of the lower horseshoe piece or against the Lock Jaw Assembly. Damage to the Lock Jaw Assembly may result and not allow smooth operation of the closing mechanism.

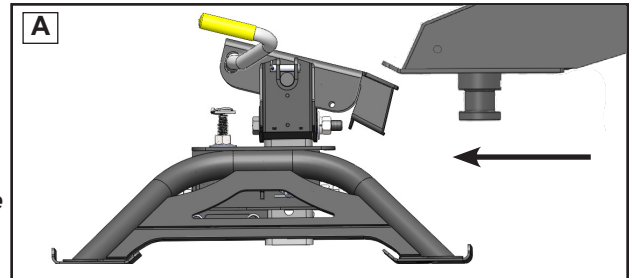

4. The Fifth Wheel Latch must be in the open position, (Fig. B, also see pages 8,9). Lift and pull out on the Release Handle to open the Lock Jaw Assembly.

**CAUTION:** Damage will result if you attempt to hook up with the Lock Jaw Assembly in the closed position.

5. Back up the truck in one fluid motion and without hesitation so the king pin enters the center of the Fifth Wheel Plate, activating the Lock Jaw mechanism.

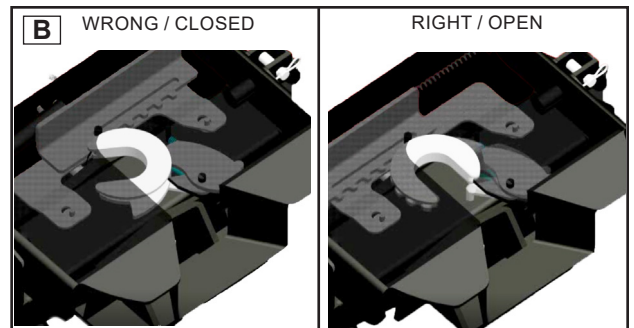

## SAFETY CHECKS PRIOR TO TOWING

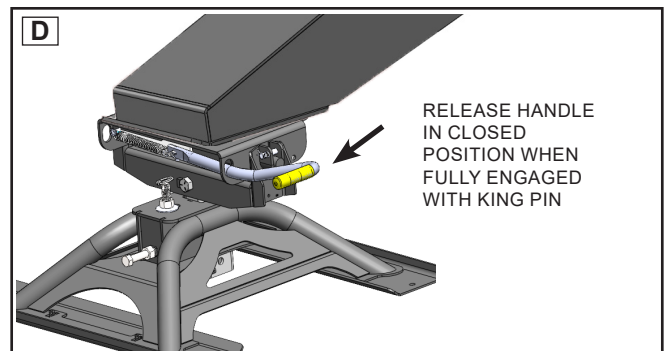
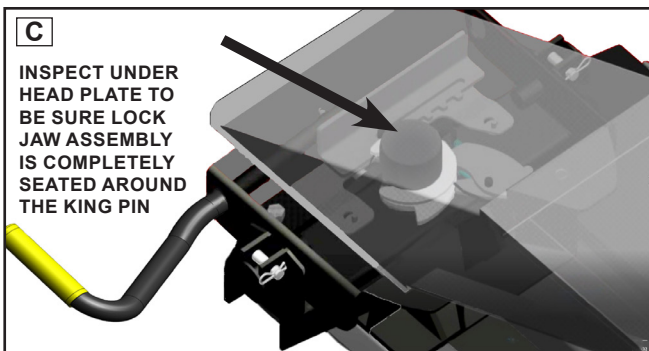

1. Prior to towing, it is imperative to know if you are hooked up properly and the king pin is engaged:
  - With a flashlight, visually inspect under the head plate to be sure the Lock Jaw Assembly is completely seated around the king pin (Fig. C).
  - Give the handle a tug to be sure that the Release Handle has fully returned to the closed position (Fig.D).
2. Raise the trailer jack base plates just above the ground, lock your trailer brakes, then pull the tow vehicle slowly forward putting a strain on the trailer.
3. When you are assured that the trailer is safely hooked up, raise your trailer jacks into their fully retracted position.

**FAILURE TO PERFORM THESE SAFETY CHECKS MAY RESULT IN DAMAGES TO TRUCK AND TRAILER.**

# UNHITCHING

**WARNING:** *Never perform any of the following actions while any part of a person is between the vehicle and the trailer.*

1. Once you have the trailer located and are ready to unhitch, block the trailer wheels so it will not roll back or forward. Back into the blocked trailer slightly and set the parking brake while you are still in gear. This action will relieve pressure on the lock mechanism before attempting to release the latch mechanism.
2. Lower the trailer jacks to the point of just touching the ground but do not raise the trailer at this point.
3. Open the Lock Jaw Assembly by first lifting, then pulling the Release Handle towards you.
4. Lower the trailer jacks until the bottom of the king pin box is almost free of the top of the Fifth Wheel Plate. Make certain that the bottom of the king pin is not so high that binding on the hitch Lock Catch would result.
5. After lowering the truck's tailgate, disconnect the trailer electrical cord and break-away switch cable, then pull forward.
6. As the king pin slides from the Fifth Wheel Plate, notice that the locking mechanism remains open once the king pin is removed.

**CAUTION:** *If it should be necessary to reposition your trailer, you must follow the hitching procedures to ensure the hitch is latched before moving the trailer.*

**CAUTION:** *You may wish to keep the plate closed until you are ready to re-hitch to avoid injury or accidents to children or adults who attempt to operate the plate mechanism.*



**DO NOT ATTEMPT TO TRIP THE LOCK MECHANISM WITH YOUR HAND, USE A PROBE TO SIMULATE THE KING PIN.**

## CHALLENGE VS. SOLUTION

CHALLENGE	SOLUTION
Cannot open the Release Handle	You may have too much rearward pressure against the lock mechanism. Back your truck slightly to relieve pressure and continue the unhitching procedures.
Plate seems dry - Can I use a lubrication disk?	Yes you can.
Trailer overhang is hitting the truck bed rails when the trailer and truck are at sharp angles.	Raise or lower the hitch plate height and/or lower the king pin box. There should be at least 6" between the top of the bed rails and bottom of the trailer.
The latch handle mechanism seems too stiff to operate.	Spray the locking mechanism with WD-40. Work the handle until it slides freely. If the problem persists, you may need to degrease and re-lube all working parts.
I need to have a professional evaluate my Super 5th.	Contact PullRite's Customer Service Dept. at (800) 443-2307. Your needs will be assessed and resolved by PullRite or you will be directed to an authorized PullRite Service Center.

## RELATED ACCESSORIES

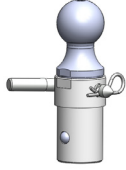
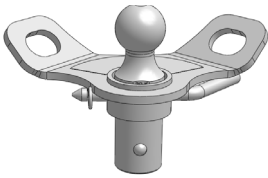
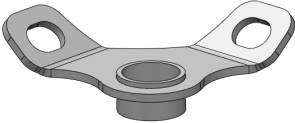
PullRite offers these excellent accessories for towing with the #3900 hitch. These products are American made and available now through PullRite dealers.

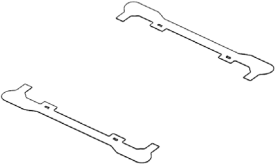
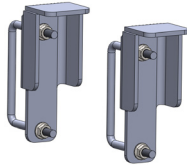
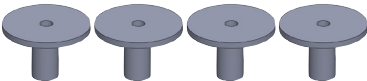
IMAGE	DESCRIPTION	PART #
	<p><b>30K OE Series Gooseneck Ball</b></p> <ul style="list-style-type: none"> <li>-Fits truck's factory-equipped Tow Prep Package.</li> <li>-American made with patented TwistLock technology.</li> <li>-Zinc finish.</li> </ul>	4436
	<p><b>30K OE Series Gooseneck Ball w/ Plate</b></p> <ul style="list-style-type: none"> <li>-Fits truck's factory-equipped Tow Prep Package.</li> <li>-American made with patented TwistLock technology.</li> <li>-Hard nickel finish resistant to scratches.</li> </ul>	4437
	<p><b>30K OE Series Gooseneck Ball Chain Plate</b></p> <p>A companion piece for the OE Series Gooseneck Ball.</p>	443701
	<p><b>Slip Plate Dry Graphite Lubricant Spray</b></p> <p>Case of 12 - 12 ounce cans.</p> <p>Single 12 ounce can - #33040301</p>	330403
	<p><b>Lube Plate Kit for Bed Saver Rails</b></p> <p>Eliminates the need for lubricant where the rails make contact with the hitch.</p>	2618
	<p><b>GM Support Bracket Kit</b></p> <p>Gives needed support for GM truck beds (2010-Present) to reach load capacity ratings when using the Pullrite Super 5th #3700. (Set of 2)</p>	2616
	<p><b>GM OE Puck Plug Kit</b></p> <p>Gives needed support for GM OE truck beds to reach load capacity ratings when using the Pullrite Super 5th #3700. (Set of 4)</p>	2620

## TORQUE TABLE

Apply these torque specifications for the corresponding items listed below upon installation and subsequent inspections of the #3900. See parts list (pg. 17) for identification of items listed on this table.

HARDWARE	SIZE	TORQUE SPECS
PIVOT BOLT	3/4"	<b>60 FT. LBS</b> - ONE BOLT TIGHTEN ROCKER ARM TO BASE
COLUMN SET SCREW	5/8"	<b>45 FT. LBS</b> - TWO BOLTS AND SNUG TIGHTEN NUTS
DRAW DOWN NUT	3/4"	<b>60 FT. LBS</b> - ONE NUT TIGHTEN TO DRAW DOWN BOLT
GOOSENECK RECEIVER SET SCREW	5/8"	<b>45 FT. LBS</b> - ONE BOLT AND SNUG TIGHTEN NUT

# EXPLODED VIEW

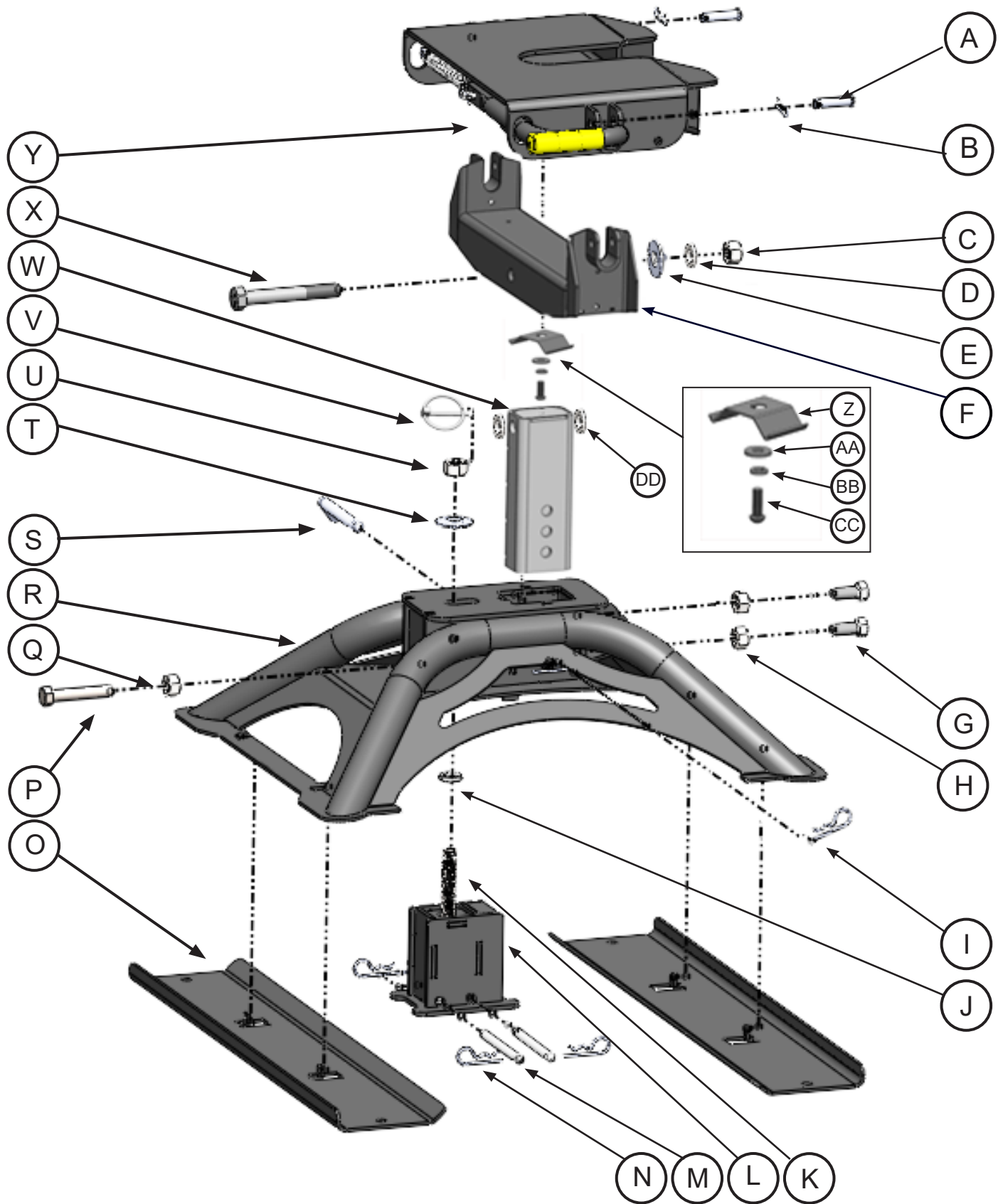



# #3900 PARTS LIST

ITEM	NAME	PART NO.	QTY	DESCRIPTION
A	HEAD PLATE CLEVIS PIN	98410111	2	1/2" X 2" CLEVIS PIN
B	HEAD PLATE HITCH PIN CLIP	98410127	2	#3 HITCH PIN CLIP
C	PIVIOT NUT	98150131	2	3/4"-10 HEX NUT
D	PIVIOT LOCK WASHER	98200124	1	3/4" LOCK WASHER
E	PIVIOT FLAT WASHER	98250190	1	3/4" FLAT WASHER
F	ROCKER ARM	390201	1	
G	COLUMN SET SCREW	98010231	2	5/8" X 1 1/2" HEX CAP SCREW
H	COLUMN SET SCREW NUT	98150176	2	5/8" - 11 HEAVY HEX NUT
I	COLUMN PIN CLIP	98410143	1	# 9 PIN CLIP
J	PALNUT	98410526	1	3/4 - 10 - 6 NOTCH PALNUT
K	DRAW DOWN BOLT	26020207	1	CARRIAGE BOLT
L	GOOSENECK RECIEVER	390501	1	GOOSENECK RECIEVER
M	SUPERLITE RELEASE PIN	26020206	2	5/8 PIN - 0.625 DIA.PINS
N	SUPERLITE RELEASE PIN CLIP	98410143	4	# 9 PIN CLIP
O	BED SAVER RAIL	26030101	2	BED SAVER RAIL
P	GOOSENECK RECIEVER SET SCREW	98010232	1	5/8" X 3 1/2" HEX CAP SCREW
Q	GOOSENECK RECIEVER SET SCREW NUT	98150176	1	5/8-11 X 3 1/2 HCS
R	#3900 HITCH BODY	390401	1	
S	ADJUSTMENT HITCH PIN	010019	1	1/2" HITCH PIN
T	CONICAL TOOTH WASHER	98200173	1	3/4" CONICAL TOOTH WASHER
U	DRAW DOWN NUT	98150131	1	3/4"-10 HEX NUT
V	LINCH PIN	98410525	1	3/16 LINCH PIN
W	ADJUSTABLE COLUMN	3903	1	
X	PIVOT BOLT	98010139	1	3/4"-10 X 7" HEX CAP SCREW
Y	HEAD PLATE ASSEMBLY	3601	1	
Z	ROCKER ARM SPRING	39030103	1	5/16"-18 X 3/4" Zinc Plated Button Head SCS
AA	SPRING ASSEMBLY FLAT WASHER	98250160	1	5/16" LOCK WASHER
BB	SPRING ASSEMBLY LOCK WASHER	98200159	1	5/16" FLAT WASHER
CC	SPRING ASSEMBLY SCREW	98010243	1	
DD	LARGE NYLON WASHER	41030405	2	3/4 NYLON WASHER

# 5 YEAR LIMITED WARRANTY

PULLIAM ENTERPRISES, INC. hereinafter referred to as "PULLIAM", warrants to the first retail owner only, this PullRite towing system to be free from defects in materials and workmanship for a period of five (5) years or 31,068 miles (50,000 km) after the installation on purchaser's vehicle, whichever occurs first.

To validate this warranty, the first retail owner must mail the provided warranty card to PULLIAM, or register online at [www.pullrite.com](http://www.pullrite.com), within ten (10) days after installation of said towing system on his vehicle.

The owner is responsible for all normal and preventative maintenance described in the Owner's Manual.

If any defect occurs which the owner believes is covered by this warranty within said five (5) year period, the owner shall contact PULLIAM immediately, either in writing or by telephone call, Attention Customer Service Department. The owner will be instructed to return the hitch at his expense either to an authorized PullRite dealer or to PULLIAM to repair or replace any parts necessary to correct defects in material or workmanship.

Repair or replacement shall be at the sole option of PULLIAM and shall be completed by or on behalf of PULLIAM free of charge for materials and labor.

This warranty gives you specific legal rights, and you may also have other rights which vary from state to state.

## THIS WARRANTY SPECIFICALLY *EXCLUDES* EACH OF THE FOLLOWING:

1. Defects in the product resulting from misuse, neglect, accident, loading beyond the vehicle's capacity, failure to comply with instructions contained in the Owner's Manual or unauthorized repairs, replacements, alterations or modifications. "Unauthorized repair, replacements, alterations" are those made without PULLIAM'S prior knowledge and consent.
2. Any incidental or consequential damage including, but not limited to, loss of use of the vehicle, towing charges, vehicle rental, loss of time, inconvenience, travel, gasoline, lodging and telephone expenses, loss of revenue and damages on account of personal injury and property damage. (Some states do not allow the exclusion or limitation of incidental or consequential damages, so these limitations may not apply to you).
3. Repairs or replacements of defects in any PullRite towing system, or part thereof, installed on any vehicle which has been rented, leased or used for any commercial purpose.
4. Any representation, warranty of undertaking made by any dealer or third party beyond the scope of the warranty herein expressed.
5. Any problem resulting in normal deterioration due to wear or exposure.

TO THE EXTENT PERMITTED BY LAW, IMPLIED WARRANTIES OF MERCHANTABILITY AND FITNESS FOR A PARTICULAR PURPOSE ARE LIMITED IN DURATION TO FIVE YEARS FROM THE DATE OF INSTALLATION ON THE FIRST OWNER'S VEHICLE. (SOME STATES, HOWEVER, DO NOT ALLOW LIMITATIONS AS TO DURATION OF IMPLIED WARRANTY, SO THOSE LIMITATIONS MAY NOT APPLY TO YOU)



# Product Warranty Registration

As an owner of a PullRite product, you must register your product to be considered for warranty coverage. See Owners Manual for further details.

***Please note, that you can also register online at [www.pullrite.com/warranty.htm](http://www.pullrite.com/warranty.htm).***

Name: \_\_\_\_\_

Address: \_\_\_\_\_

City: \_\_\_\_\_ State: \_\_\_\_\_ Zip: \_\_\_\_\_

Email Address: \_\_\_\_\_

Phone (optional): \_\_\_\_\_

Purchase Price: \_\_\_\_\_ Date of Purchase: \_\_\_\_\_

Dealer's Name: \_\_\_\_\_

Dealer's Address: \_\_\_\_\_

Dealer's City: \_\_\_\_\_ Dealer's State: \_\_\_\_\_ Dealer's Zip: \_\_\_\_\_

Dealer's Phone: \_\_\_\_\_

Model Purchased: \_\_\_\_\_

Vehicle Make: \_\_\_\_\_ Vehicle Model: \_\_\_\_\_ Vehicle Year: \_\_\_\_\_

Vehicle Year: \_\_\_\_\_ Vehicle Cab Style: \_\_\_\_\_ Vehicle Bed Length: \_\_\_\_\_

Did you receive an Owners Manual from the Dealer? Yes / No

What influenced you to buy your hitch? \_\_\_\_\_

Comments:



*MANUFACTURED BY:*

PULLIAM ENTERPRISES, INC.  
13790 East Jefferson Blvd.  
Mishawaka, IN 46545  
(574) 259-1520 • (800) 443-2307  
info@pullrite.com • www.pullrite.com