

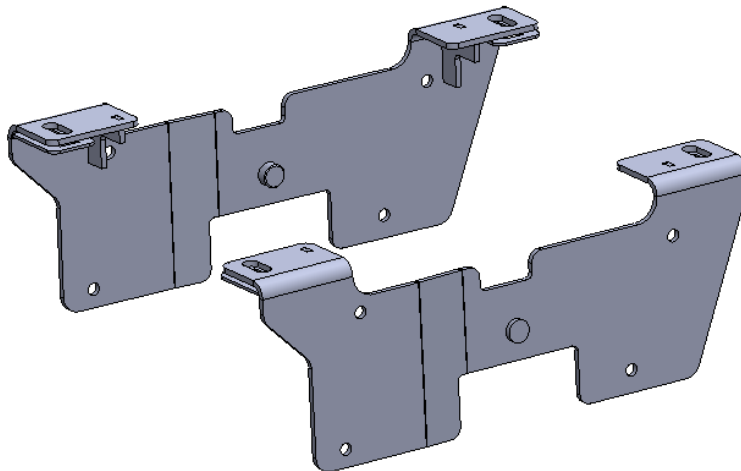

CHEVY/GMC 1500

20K Industry Standard Rail Custom Mounting Kit

#2768



Gross Trailer Weight (Maximum).....20,000 lbs.
Vertical Load Weight (Max. Pin Weight)5,000 lbs.

SYSTEM TOW CAPACITY

Please note, in order to determine the total tow capacity of a system, you must consider the weight ratings of each component in that system. This includes, but may not be limited to, the capacity / rating of the tow vehicle, the fifth wheel hitch, and the hitch's mounting system. Actual tow capacity of the system will be equal to the lowest rated component.

Installation Instructions

SPECIFICATIONS

- Fits 2019 Chevy 1500 & GMC 1/2 ton trucks (new body style).
- King pin is located center of the axle.
- U.S. Patent Pending.

TABLE OF CONTENTS

PREPARATION / BRACKET NUT TAB.....	3
MOUNTING KIT EXPLODED VIEW.....	4
MOUNTING KIT PARTS LIST.....	5
MARKING THE TRUCK BED FOR DRILLING.....	6
LAYOUT METHOD.....	6
TEMPLATE METHOD.....	7
INSTALLATION.....	8
PART 1 — PLACEMENT & BED HOLE LOCATIONS.....	8
PART 2 — BRACKET INSTALLATION.....	9
PART 3 — HITCH ALIGNMENT.....	10
PART 4 — FINAL INSTALLATION PROCEDURES.....	10

PLEASE VISIT OUR YOUTUBE CHANNEL FOR
PRODUCT AND INSTRUCTIONAL VIDEOS

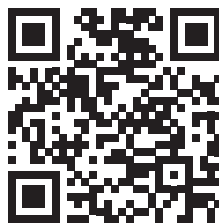

<https://www.youtube.com/user/PullRiteVideo>

PREPARATION

1. Remove the hitch from the shipping carton and check the part quantities using the Parts List on page 5.
2. Block vehicle wheels. Some vehicles may require you to raise the rear of the truck in order to make it easier to drill for installing the mounting brackets on the truck frame.
3. You may wish to remove the wheels to give yourself greater working room.
4. Read all instructions.

ISR RAILS

This PullRite mounting kit is designed to be used with ISR rails. ISR or Industry Standard Rails are a universal hitch mounting rail system used in the RV industry. Once installed, the ISR can be a cost-effective way to replace or upgrade your hitch without having to install new rails and bracket kit.

Note: Your tow package is only as strong as its weakest link, therefore If you have a 24K hitch in your truck on a 20K rail system, you can only safely tow a 20K trailer.

BRACKET NUT TAB

The Bracket Nut Tabs are a feature built into PullRite mounting brackets. They hold the 5/8" flange nuts locked in place, making it easier to install the rail kit. It eliminates the need for a wrench on the nut when tightening down the rail bolts. The bracket and tab both feature an oblong slot which allows for some tolerance left to right when installing the rails.

Instructions for the (4) tabs are as follows:

1. Bend open the tabs by pushing down with hand or pliers. (Fig. 1)
2. Place 5/8" flange nut face up to oblong slot in bracket. Make sure nut is firmly seated in the tab. (Fig. 2)
3. Bend tab back into place with nut inside. (Fig. 3)

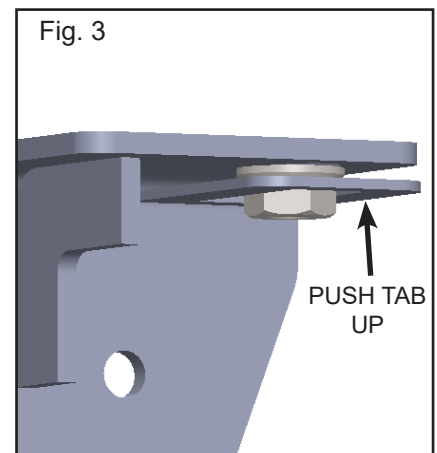
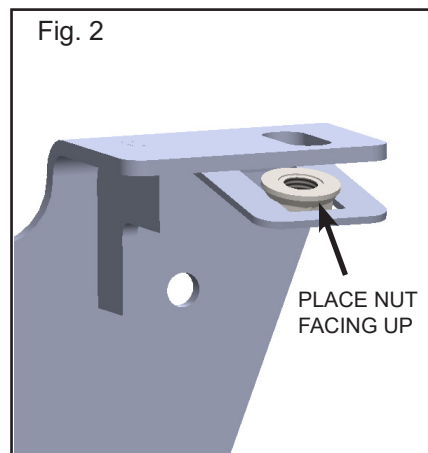
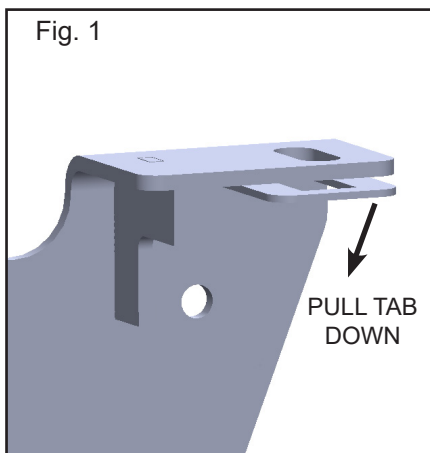

MOUNTING KIT EXPLODED VIEW

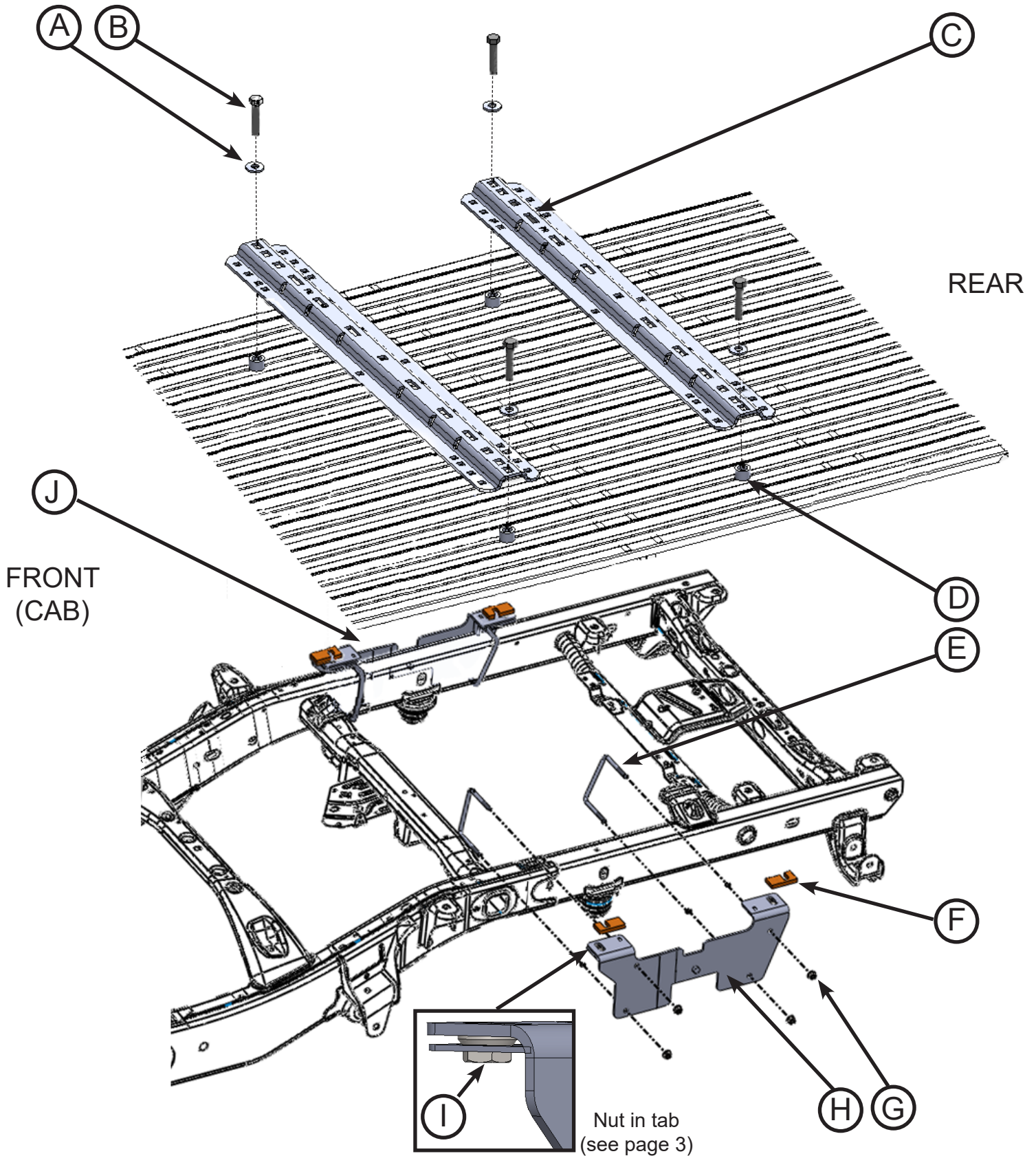

Rev B 12.18.24 RH

PARTS LIST

#2768 ISR CUSTOM MOUNTING KIT

Item	Description	Part No.	Qty.	Material
A	TOOTH CONICAL WASHER	98200171	4	5/8" X 1 1/5" EXT TOOTH CON WSHR
B	BASE RAIL BOLT	98010217	4	5/8-11 X 3" HEX BOLT ZINC PLATED GR 5
C	BASE RAILS	2719	2	ISR BASE RAILS
D	IRS SPACER TUBE	27210204	4	
E	1/2" U-BOLT	98050181	4	1/2" X 5 3/8" X 4.41 U-BOLT
F	SMALL PLASTIC SHIM	27670117	4	LEXAN MATERIAL
G	1/2"-13 SERRATED FLANGE NUT	98150201	8	1/2"-13 SERRATED FLANGE NUT ZINC
H	*DS MOUNTING BRACKET	276901	1	
I	5/8"-11 SERRATED FLANGE NUT	98150200	4	5/8"-11 SERRATED FLANGE NUT ZINC
J	**PS MOUNTING BRACKET	276902	1	
*DS = DRIVER SIDE **PS = PASSENGER SIDE				

CHEVY/GM TRUCKS WITH THE AUTO LEVEL FEATURE

This kit will not fit Chevy/GM trucks with the auto level feature without recalibrating the auto leveling system.

The brace for the auto level prevents the 2768 bracket from being placed flush against the frame.

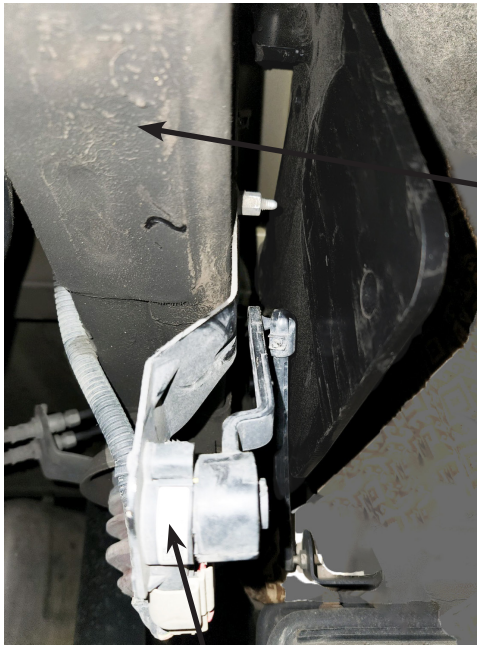

Auto level system



Auto level system brace/fastener

MARKING THE BED FOR DRILLING

LAYOUT METHOD

If you purchased an installation template, please proceed "Template Method." Templates are sold separately.

1. Referencing "Truck Bed Dimension Table" below, measure and mark from the back of the bed forward, the values for "A" and "B". Do this at any point on both sides of the bed.
2. Draw a line across the bed from mark to mark.
3. find the centerline of the bed.
4. Draw a line down the middle of the bed from front-to-rear.
5. Center the measurement of "C" across the centerline at the front-most line you made in step 2 and mark the measurement on each side (parallel to the centerline). This will locate the 4 drill holes.

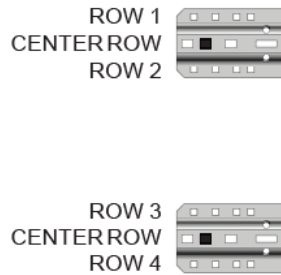
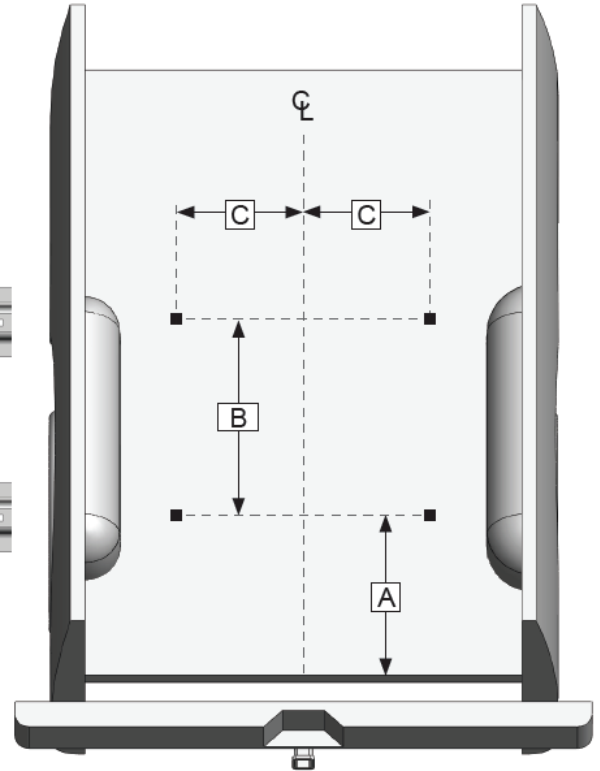

FIG. 4



BED LENGTH	TRUCK BED DIMENSION TABLE				
	LAYOUT METHOD			TEMPLATE METHOD	
	"A"	"B"	"C"	"X"	TEMPLATE PART#
5'8"	28 5/16"	22"	20 7/8"	25 7/16"	27200000
6'6"	28 5/16"	22"	20 7/8"	25 7/16"	27200000
8'	34"	22"	20 7/8"	31 1/8"	27200000

TEMPLATE METHOD

1. Lay the template in the truck bed, centering it from side-to-side, and parallel to the end of the truck bed using the dimension "X" listed below (Fig.5).
2. Mark the 4 holes as indicated below, making sure the template does not move (see Installation Tip).

INSTALLATION TIPS: The *TEMPLATE* should be orientated as shown in the drawing below. To avoid drilling holes in error from out of tolerance bed-to-frame dimensions, mark the hole locations as lightly as possible if a center or transfer punch is used. Then use a very small diameter drill bit to drill a location on one side of bed. Place the Mounting Brackets against the frame to determine the correctness of the bed hole locations relative to the pre-punched holes in the Mounting Bracket and existing frame holes. Use transparent tape to cover the mounting hole on the top of each mounting bracket (when the pilot hole is drilled through the bed, the tape will be pierced by the small drill; which should be positioned in the center of the mounting bracket hole). The template has a tendency to move when placed on the slick paint of new truck beds, and it may be helpful to place a small piece of NON-SKID matting, such as "SCOOT-GARD"™ or simply use duct tape on each corner to help keep the template from moving.

FIG. 5

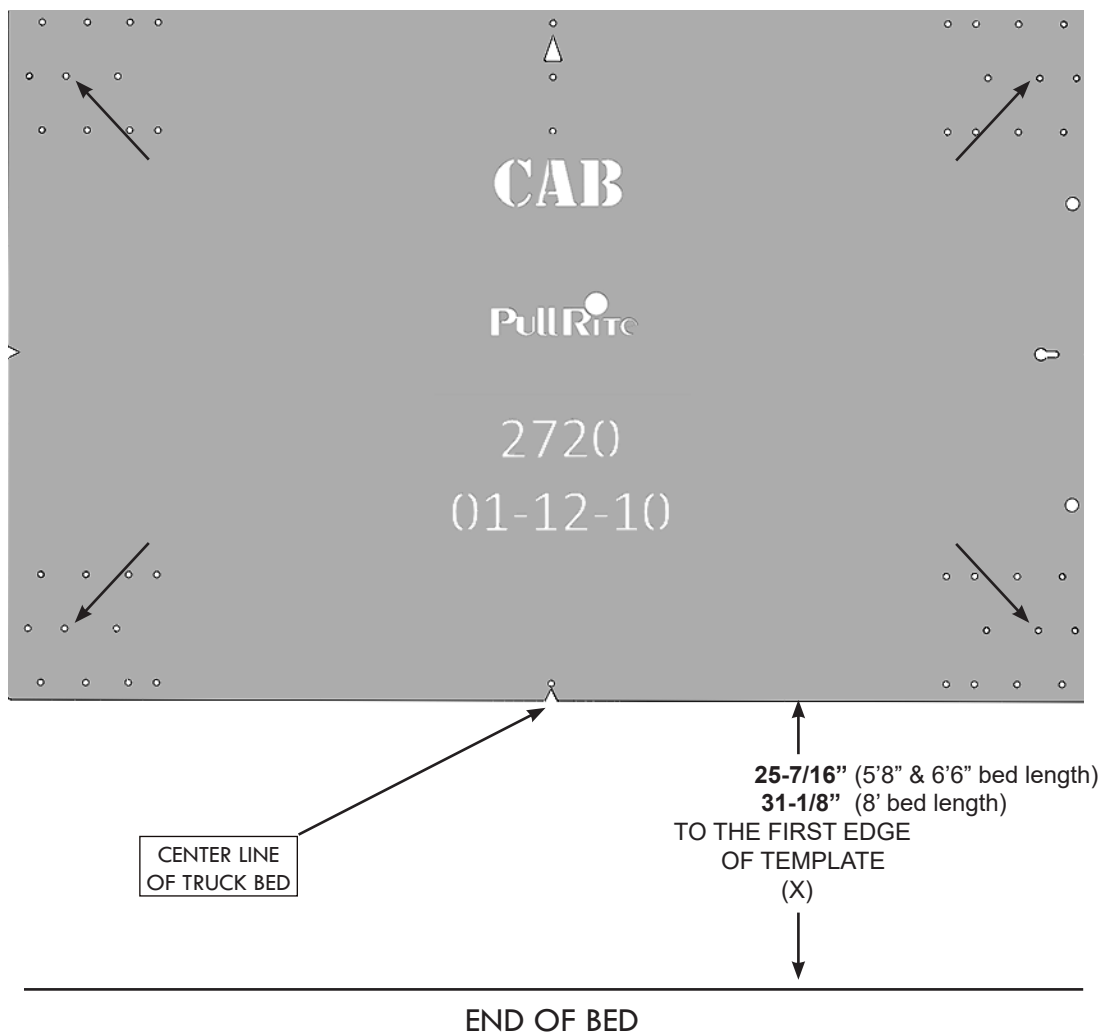

INSTALLATION

Mounting Bracket Installation

Part 1: Bracket Placement & Bed Hole Locations

Since most truck beds are not installed square to the frame or are the same distance from the back of the cab, the installer will need to make sure the bed holes line up properly with the center of each mounting post hole.

Detailed Installation Instructions

1. Use transparent tape to cover the mounting hole on the top of each mounting bracket (when the pilot hole is drilled through the bed, the tape will be pierced by the small drill; which should be positioned in the center of the mounting bracket hole).
2. Align the driver side mounting bracket by inserting the locating pin on the bracket into the existing locator hole located on the frame as seen below (Fig. 6).
3. Using the pre-punched hole on the mounting brackets as a guide, fasten brackets with the 1/2" U-bolts and 1/2" flange nuts.

FIG.6

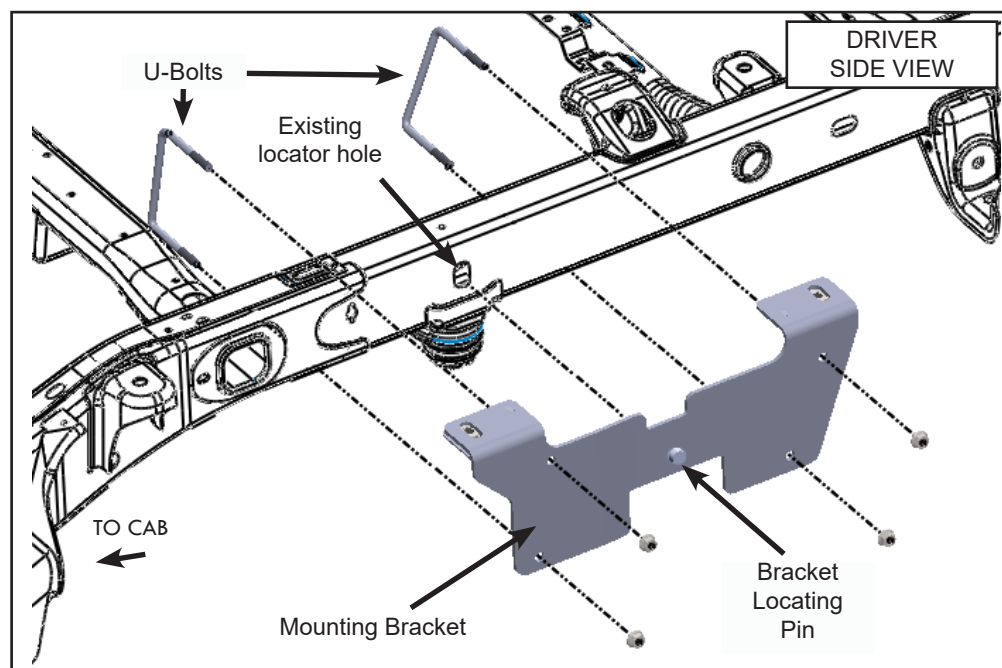

INSTALLATION

4. Drill the first 1/16" pilot hole through the truck bed over the rear mark on the driver side where you made the mark during the "Marking Bed for Drilling." The bit should come down through the bracket hole, piercing the transparent tape, aiding the centering of the bracket front-to-rear and side-to-side.

5. If the pilot hole is off-center to the bracket hole, remember to adjust **all** the pilot hole locations accordingly.

NOTE: Some truck beds are not installed square on their frame by the manufacturer. To ensure your pilot holes are aligned properly, it is important that you use the measurements provided only as a starting point and make adjustments as needed.

Once you have one pilot hole centered, you will use this hole as a point of reference for all remaining pilot hole adjustments. If you are using the Template Method, simply use the properly drilled hole as a pivot point to square the remaining holes to the frame. If you are using the Layout Method, you may accomplish the same thing by using a framing square and straight edge.

6. Repeat steps for the passenger side mounting bracket, checking carefully for proper centering.

NOTE: Final bed hole placement is dependent on the fixed position of the brackets, due to the locator pins that are inserted into the frame.

WARNING: Before proceeding to "Part 2, "Drilling the Bed...", you must verify that each obround hole is centered left to right over the hole on each mounting bracket before the holes are drilled through the bed.

Part 2: Drilling the Bed & Bracket Installation

1. Remove the mounting brackets and use a 11/16" drill centered over the 1/16" pilot hole and drill through the truck bed.

2. De-bur inside the holes.

Bracket Installation

1. Reinstall the mounting brackets to the frame by inserting the locating pin on the bracket to the existing hole in the frame, (See Fig.6 &.7).

2. Clamp the mounting brackets flush to the side of the frame using a "C" clamp.

3. Fasten the mounting bracket with the (2) U-bolts and (4) 1/2" flange nuts. Do not over tighten.

FIG. 7

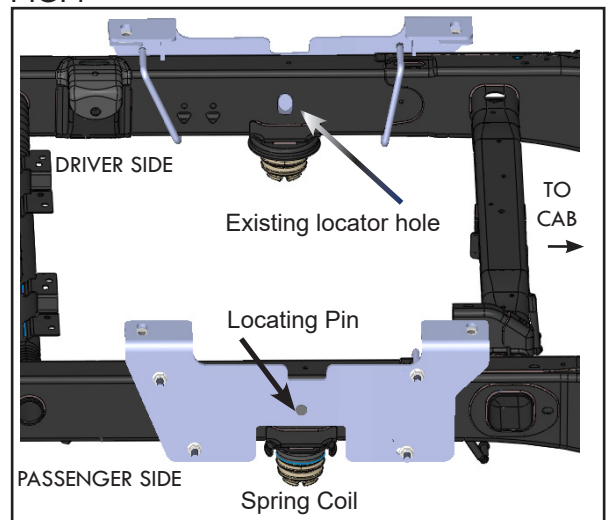

NOTE: Use a hand wrench to tighten the flange nut onto the bolts. Do NOT use an impact wrench, as this can easily strip the connection.

INSTALLATION

Part 3: Hitch Alignment

1. Install ISR rails onto the truck bed. Use the supplied 5/8" x 3" bolt placing it first through the conical washer (teeth down) and the rail into the tube spacer under the rail, and into the drilled bed hole.
2. Align nut with pencil or drift pin. Next add the Lexan shim on the underside between the mounting bracket and the underside of the truck bed (see Fig. 8). Hand tighten the (4) bolts into the 5/8" flange nuts seated in the mounting bracket nut tabs.
3. Place the hitch spades into ISR rail slots and install the hitch pins and clips to secure the hitch frame to the rails.

Part 4: Final Installation Procedures

1. Tighten 5/8" bolts according to the Torque Table below.
2. Make sure the hitch spade can be set down in rail slots without binding. You may need to loosen the bolts on the rails if binding occurs. Adjust as needed and re-tighten the bolts.

FIG. 8

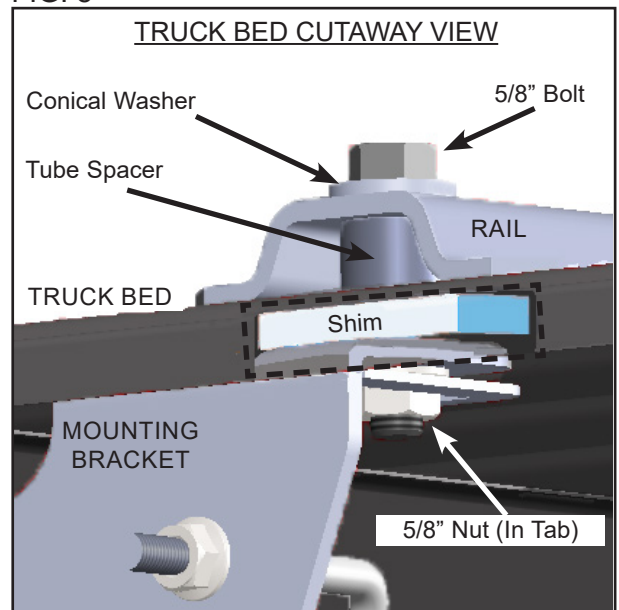

TORQUE TABLE	
3/8" Bolt	31 ft. lbs.
1/2" Bolt	75 ft. lbs.
5/8" Bolt	151 ft. lbs.
3/4" Bolt	266 ft. lbs.



MANUFACTURED BY:

PULLIAM ENTERPRISES, INC.
13790 East Jefferson Blvd.
Mishawaka, IN 46545
(574) 259-1520 • (800) 443-2307
info@pullrite.com • www.pullrite.com